



BOUNDARY SUB TECHNIQUES

Presented by;
Scott Calvert

Vancouver Train Expo 2015



WHY I CHOSE TO MODEL THE BOUNDARY SUBDIVISION



STUFF WE ARE GOING TO TRY & COVER;

- General room preparation
- Module Pre-fabrication & mass production
- Using Mock up techniques
- Styrofoam roadbed templates
- Turnout templates
- Swing gate construction
- Spline roadbed system
- Cork and roadbed
- Pre-wiring techniques
- Miscellaneous items

ROOM PREPARATION



2012 AFTER MOVE IN



CURRENT STATUS

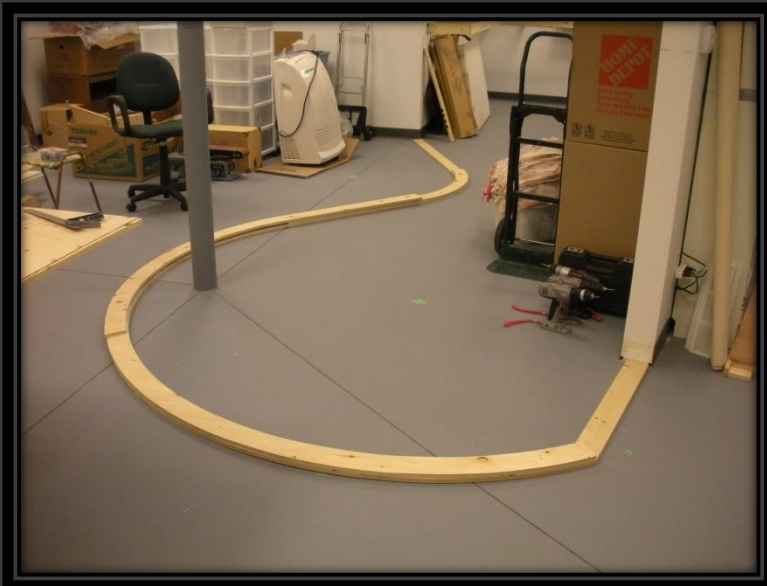

CONSTRUCTION OF
CURVED DIVIDER WALLS

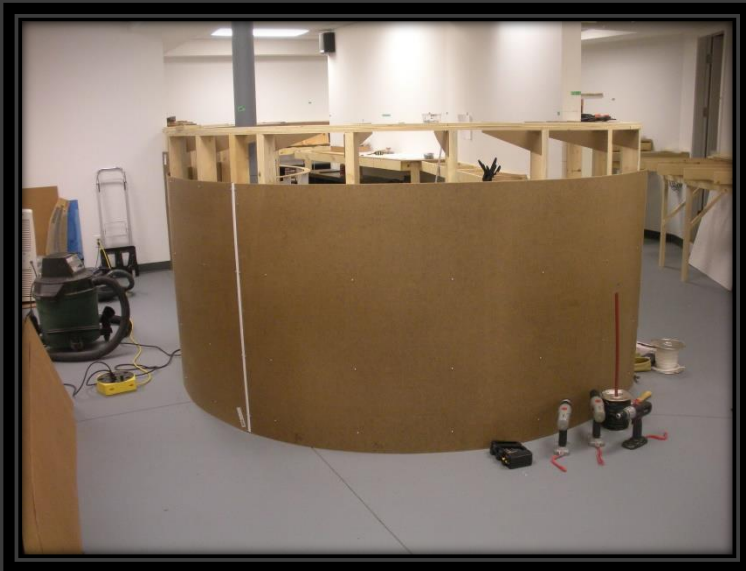





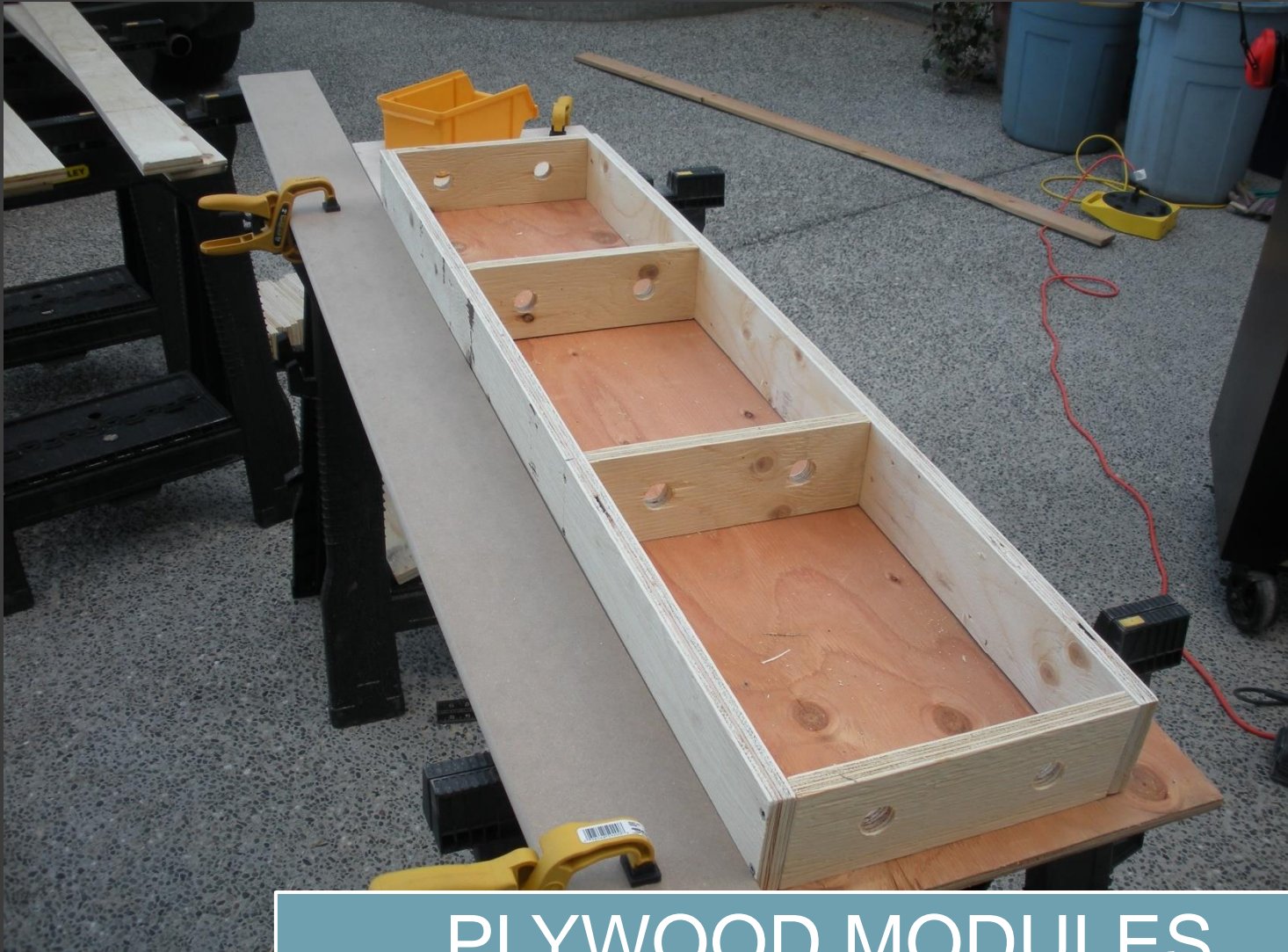

PLYWOOD MODULES

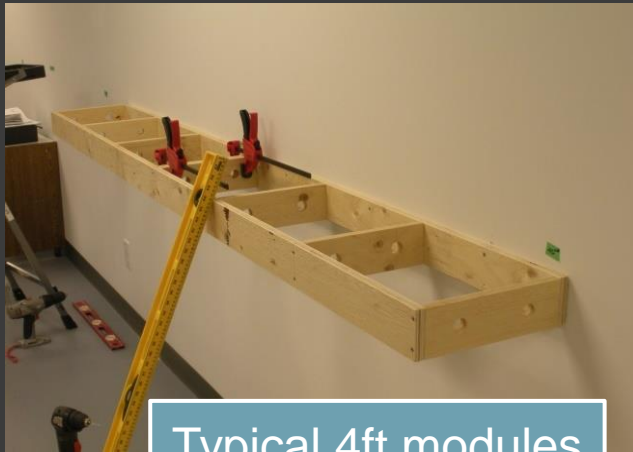

Typical 4ft modules



Double Deck

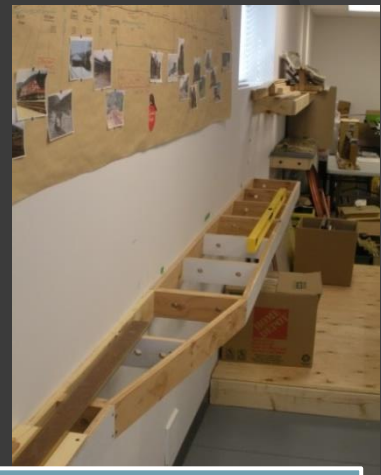

West Staging

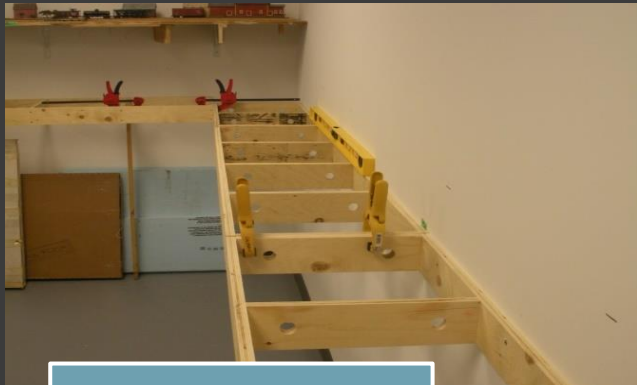

East Nelson



Proctor

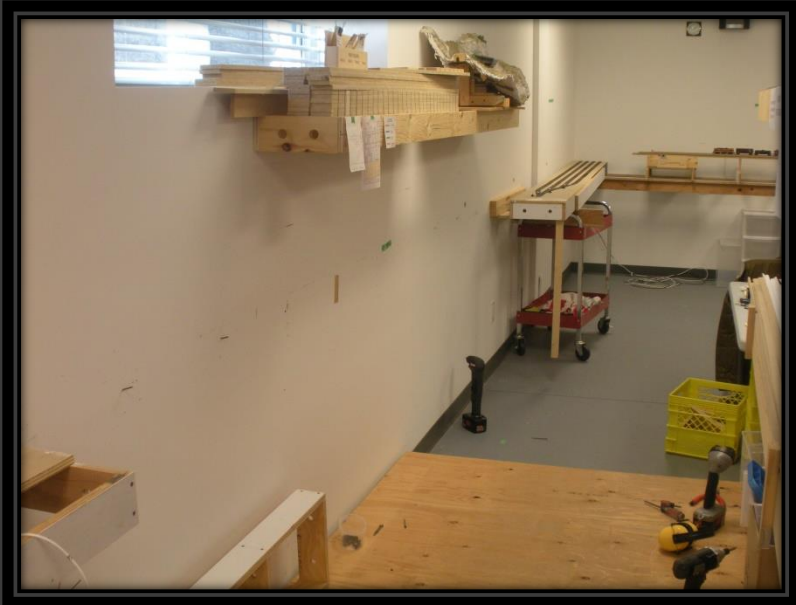



USING MOCK UPS

Main Peninsula Framing Mock up

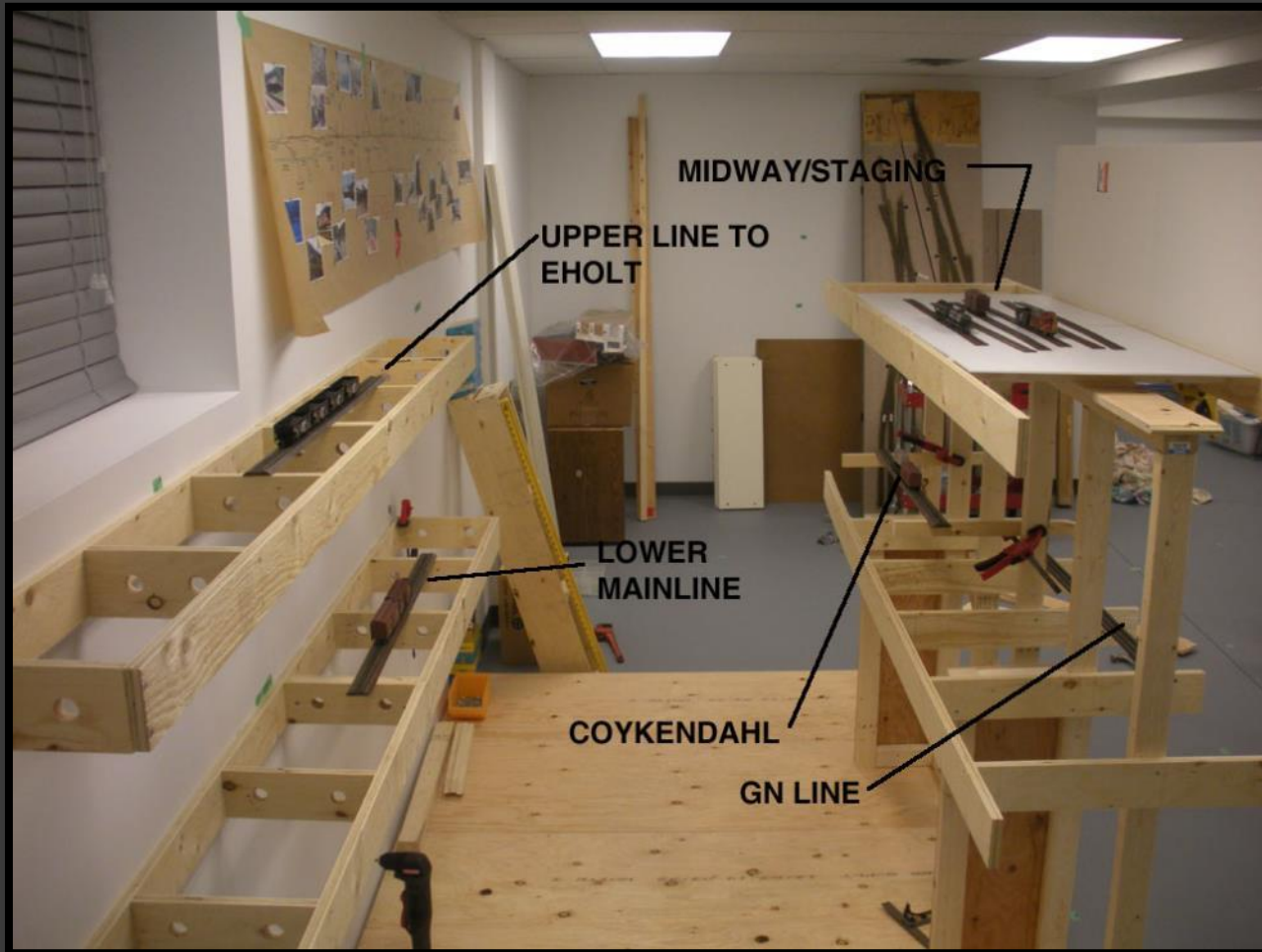

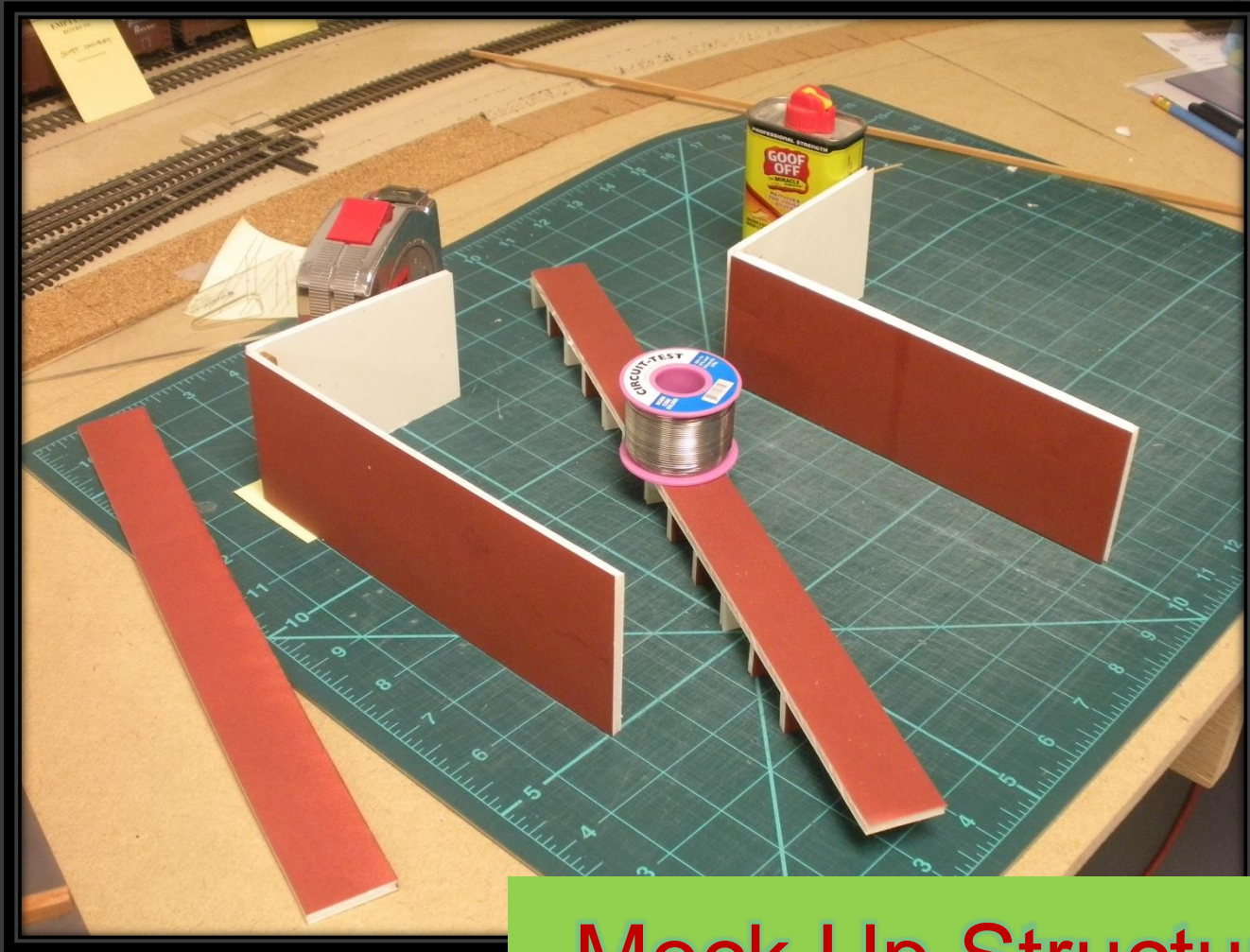

Mock Up Structures

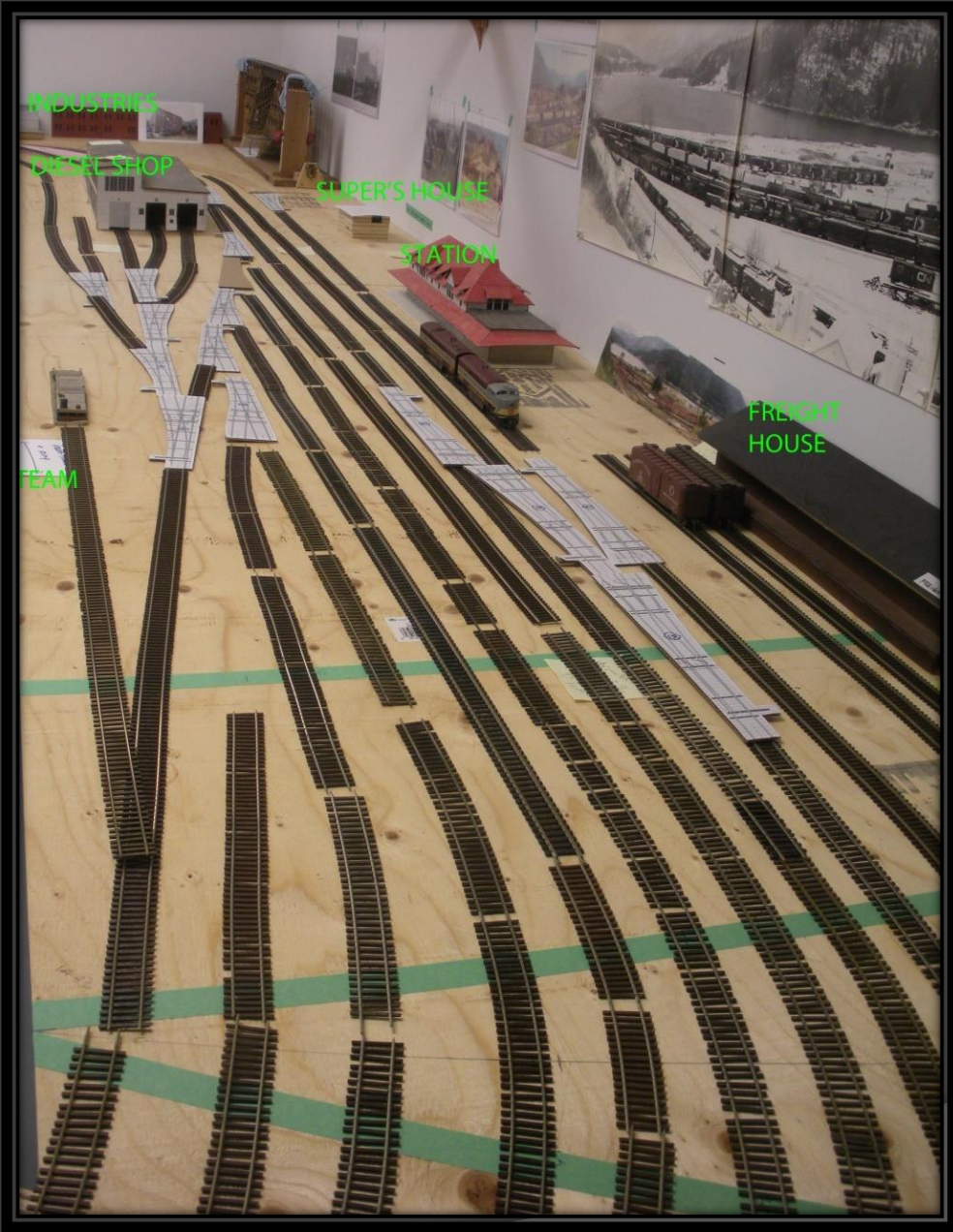

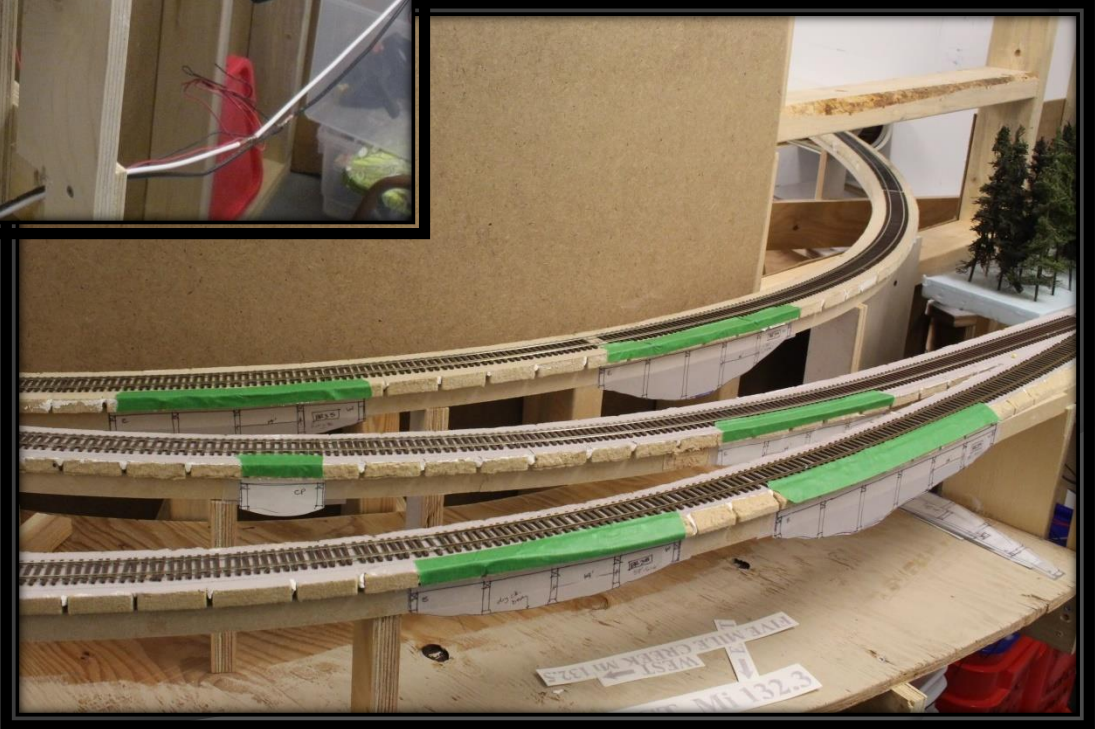
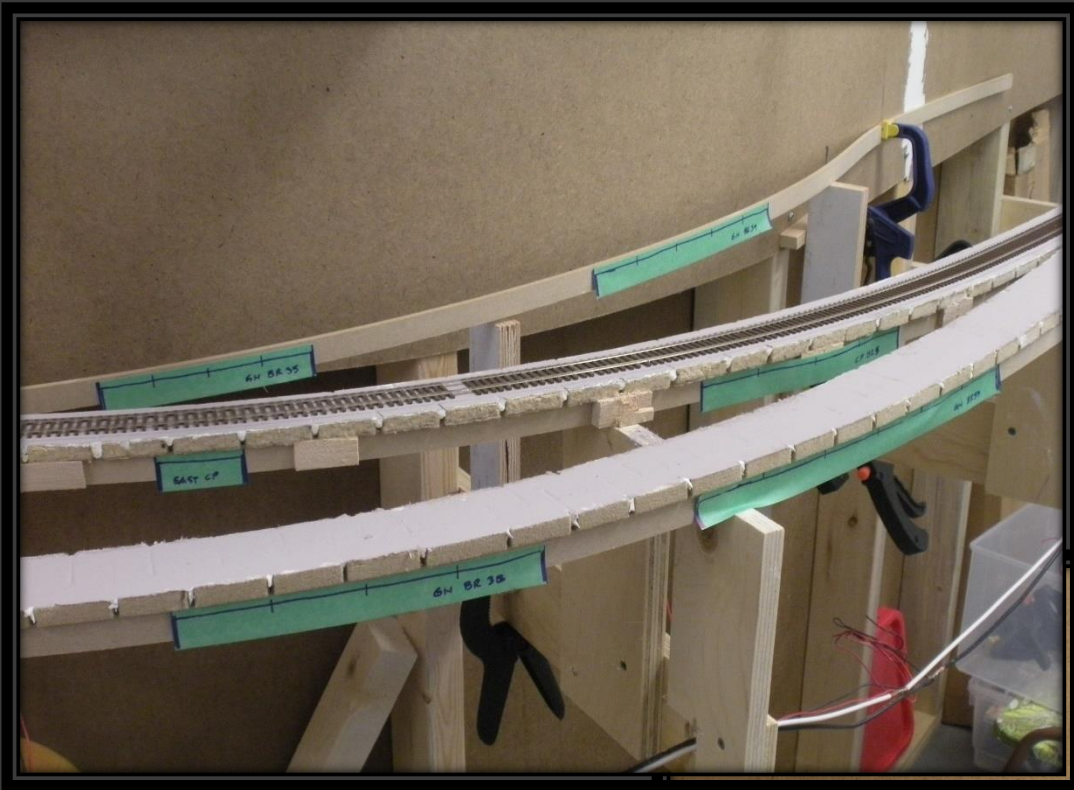

TROUP JUNCTION
TRESTLE LAYOUT

STYROFOAM ROADBED TEMPLATES

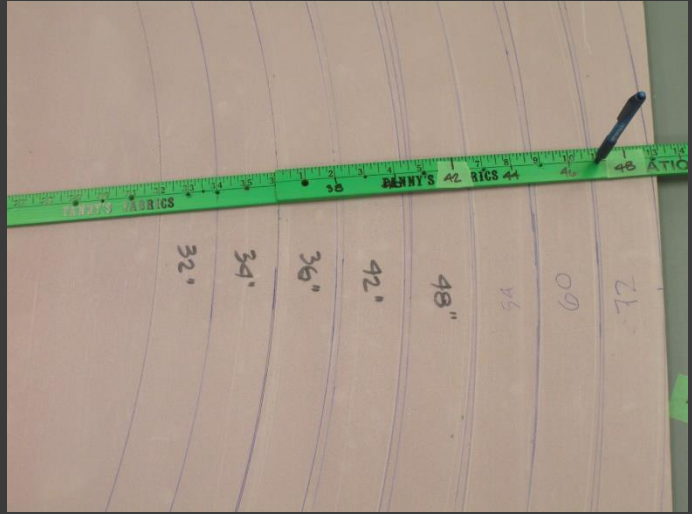
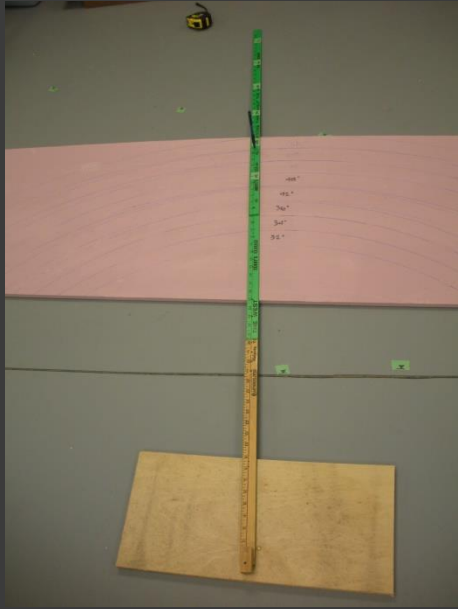

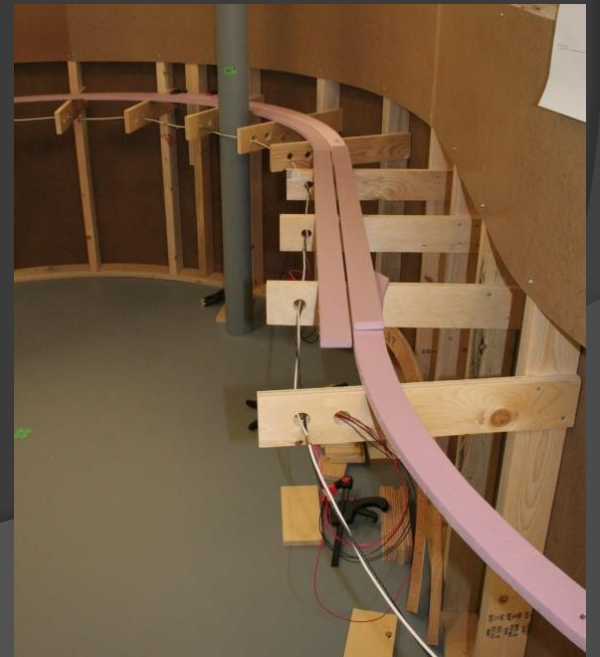
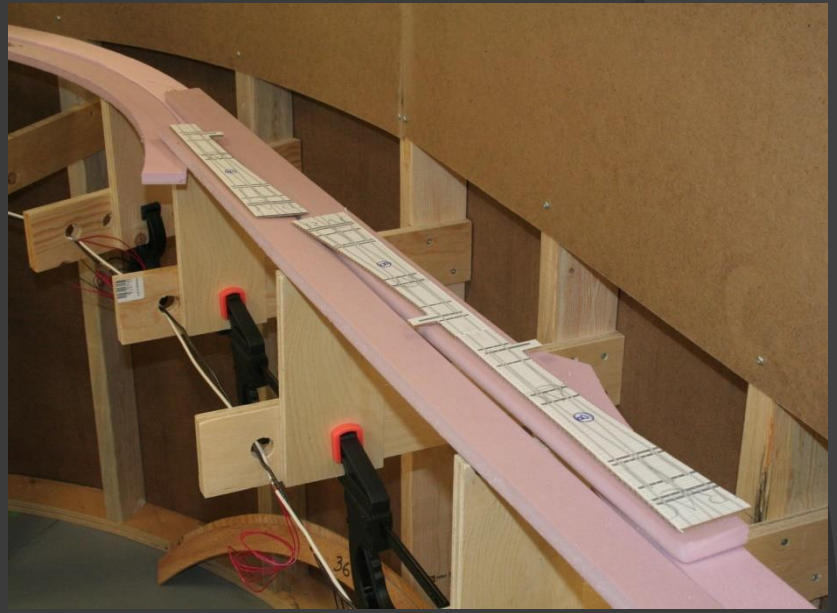
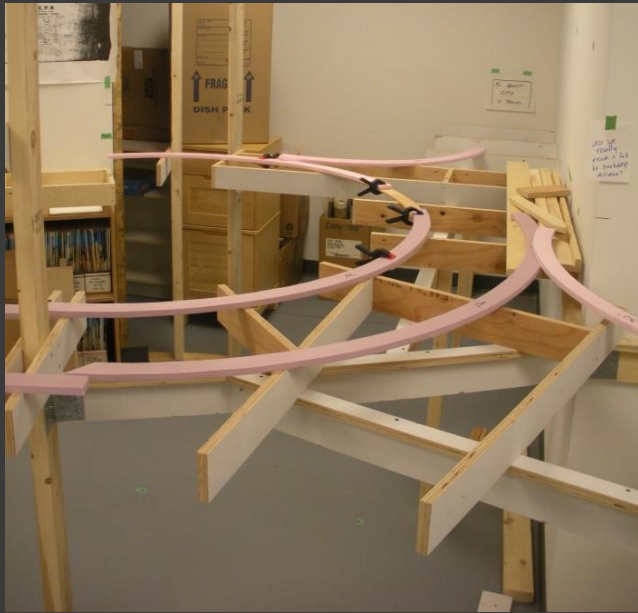

TURNOUT TEMPLATES

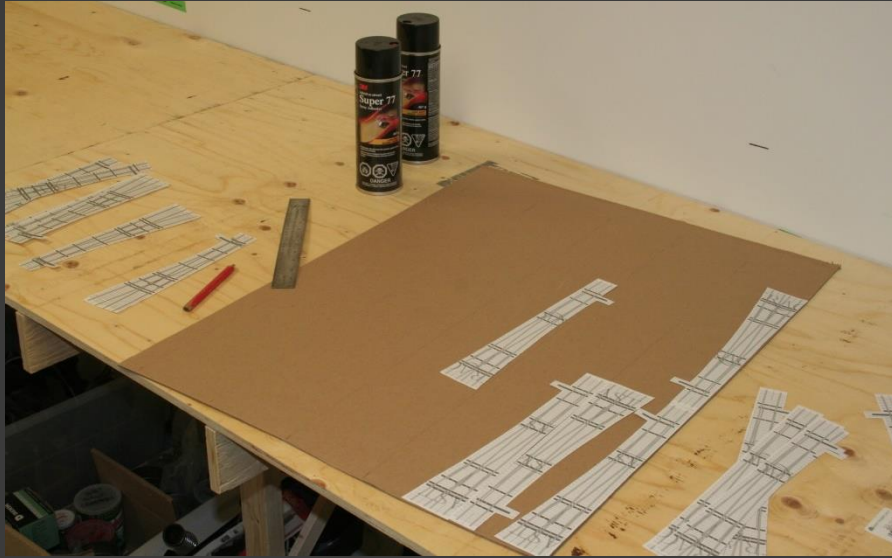

<http://www.handlaidtrack.com/Fast-Tracks-Printable-Track-Templates-s/11.htm>

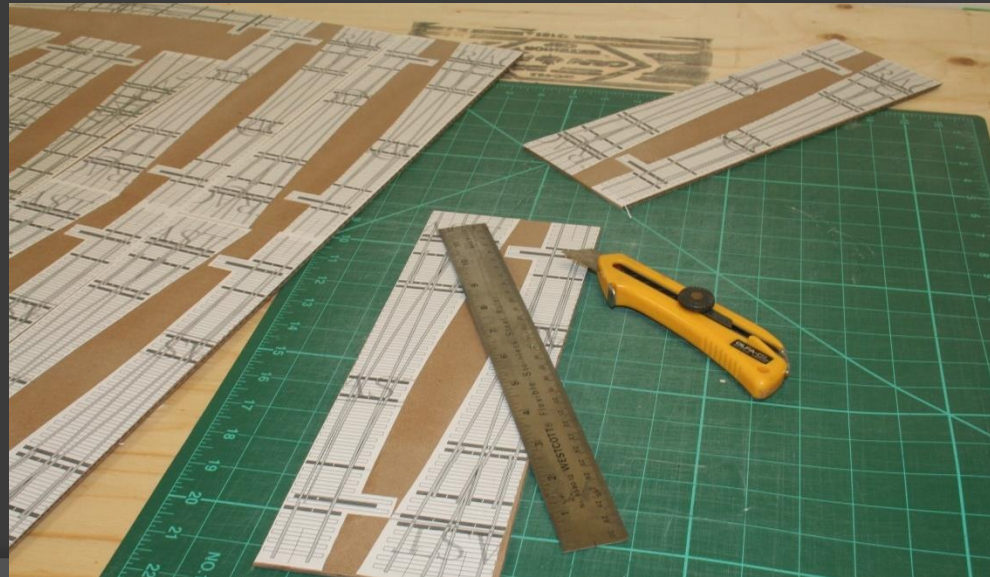
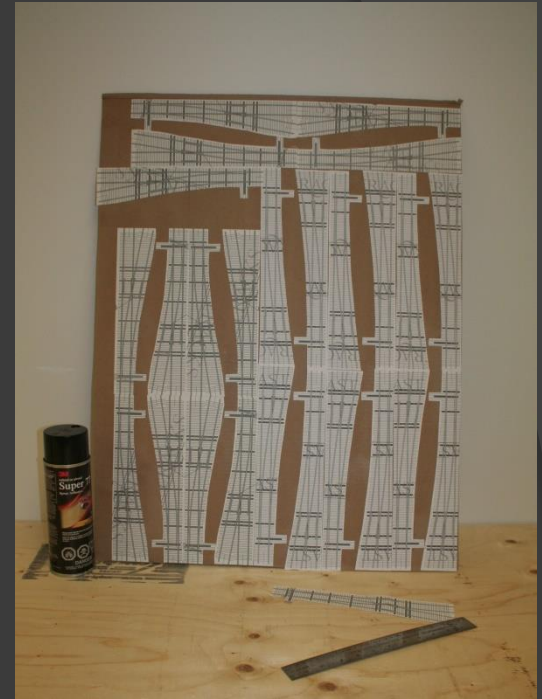

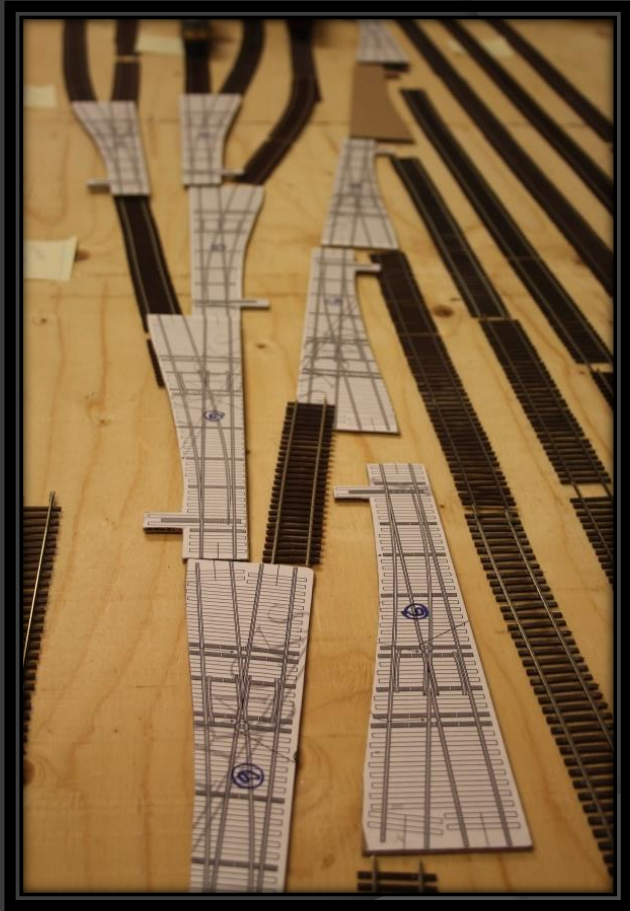

**ROOM ENTRANCE
SWING GATE
CONSTRUCTION**







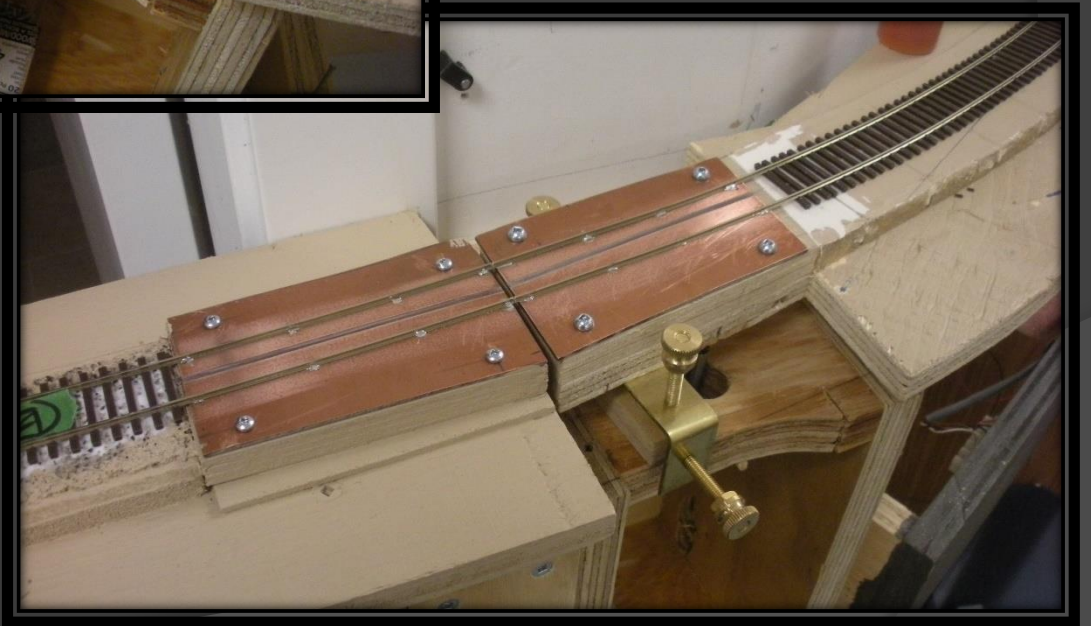
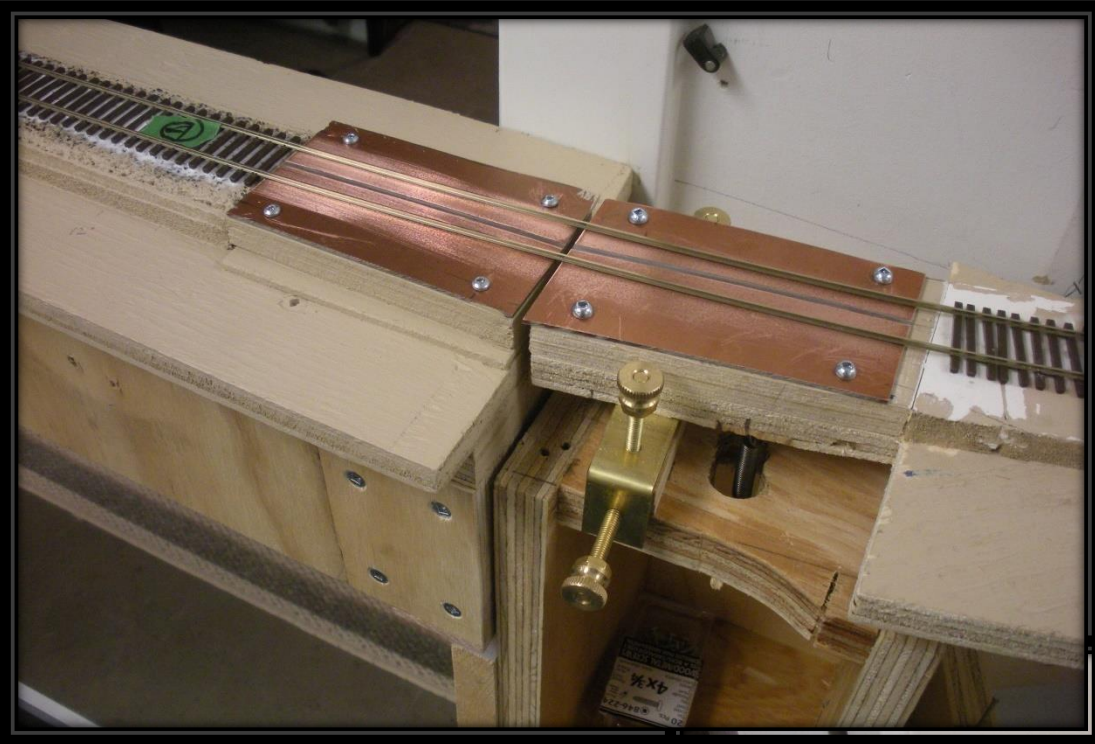





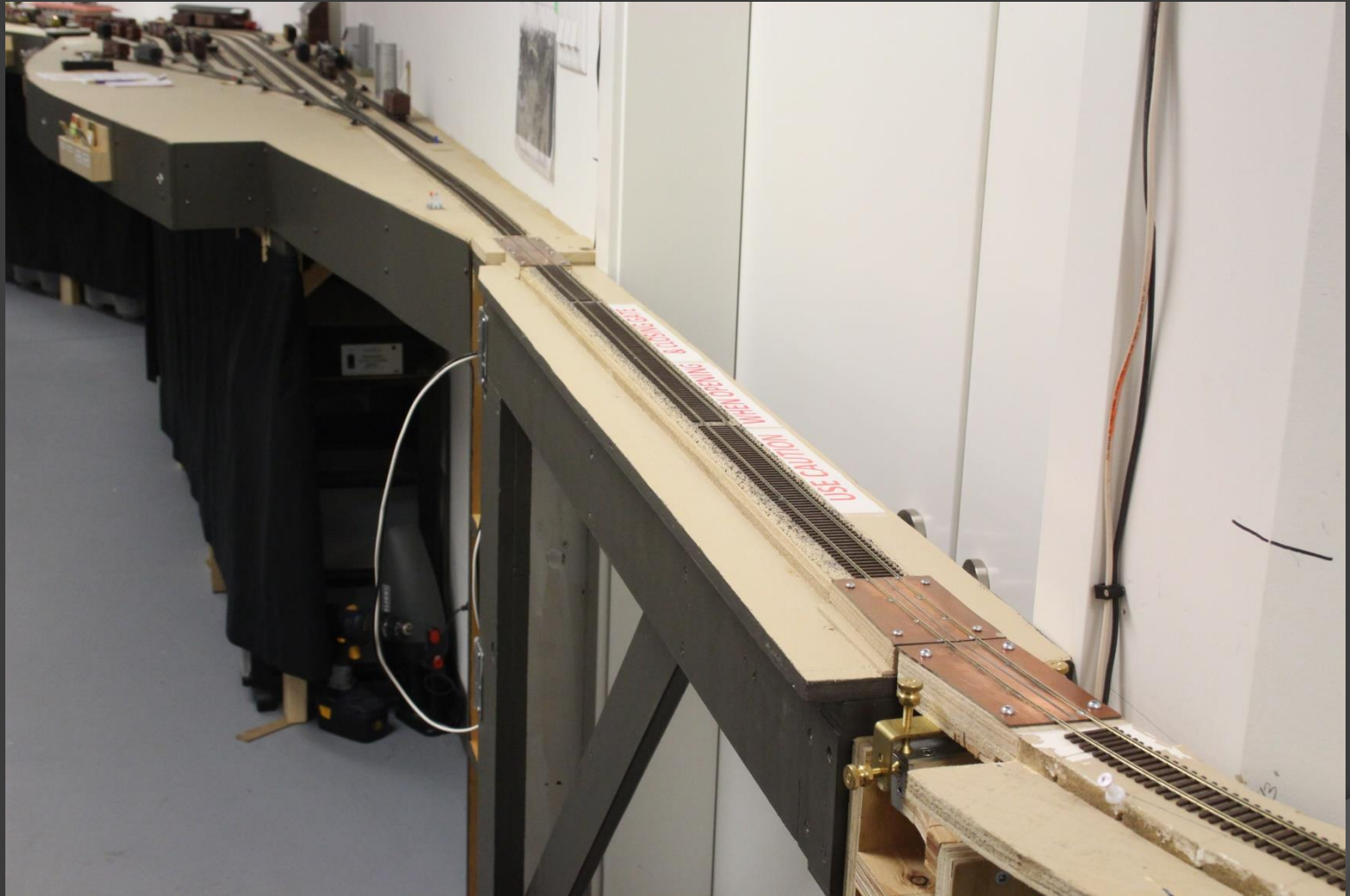







RANDOMLY SPACED BLOCKS -
USE LONGER ONES AT
SPLINE SPLICE PTS.

$\frac{1}{2}$ " W x $\frac{3}{4}$ " H
WOOD BLOCKS

5mm x $\frac{3}{4}$ "
MDF SPLINE

BLOCKS OVER RISERS
ARE NAILED & GLUED

$\frac{3}{4}$ " PLYWOOD RISERS

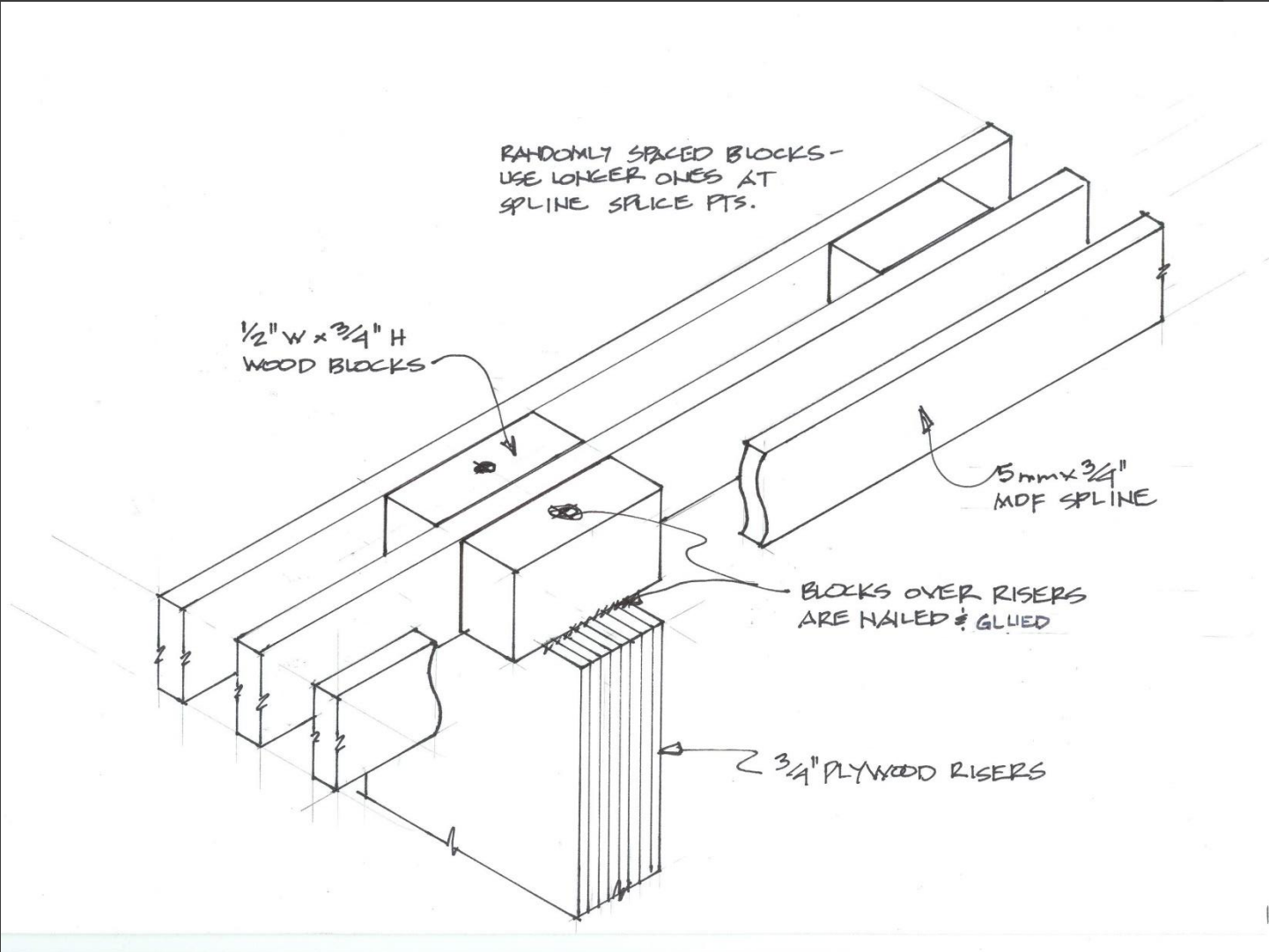



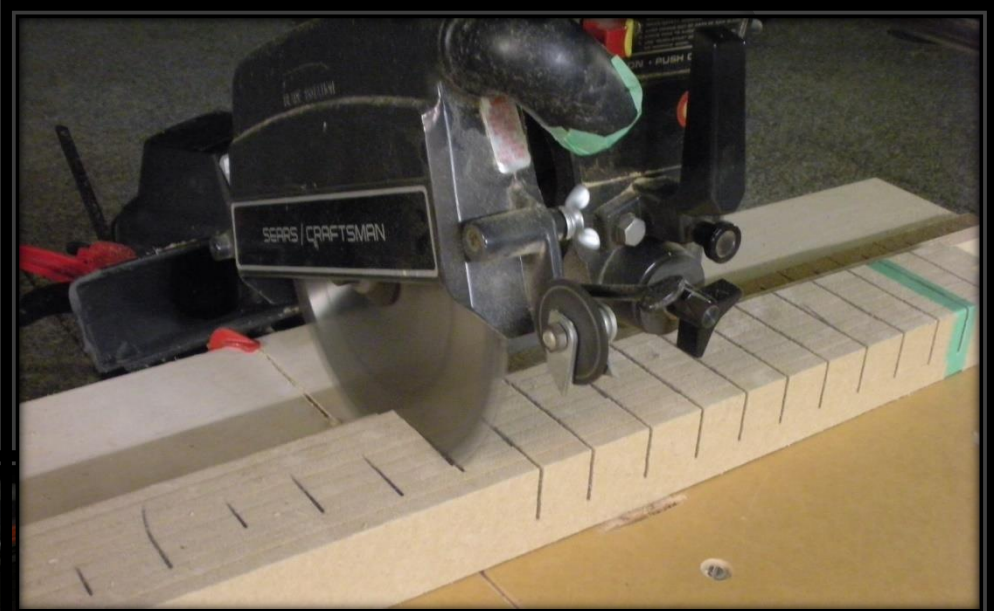

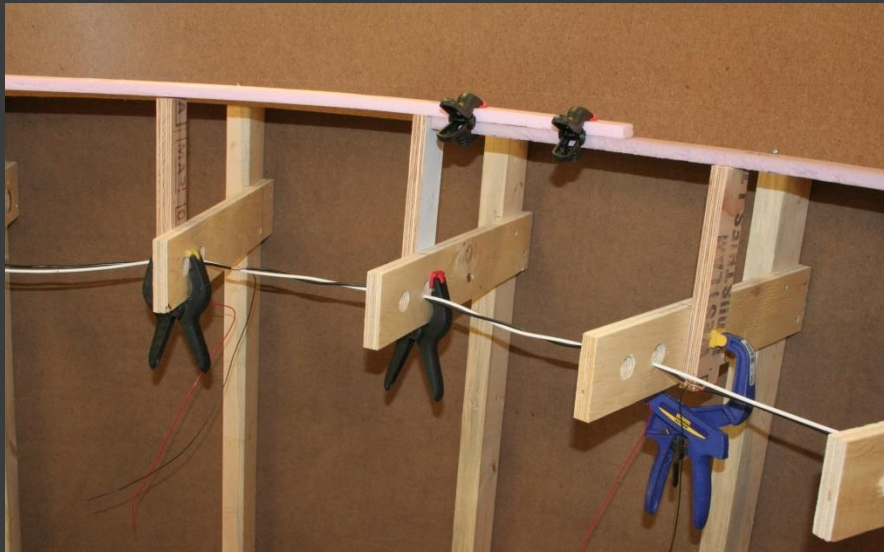
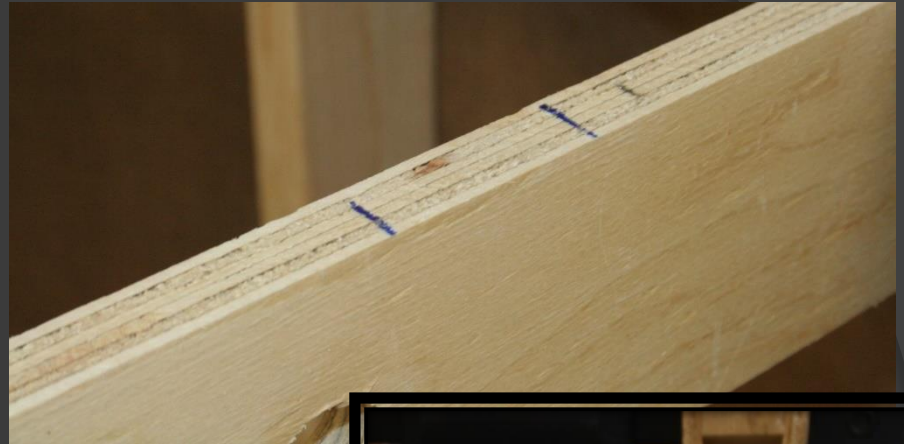

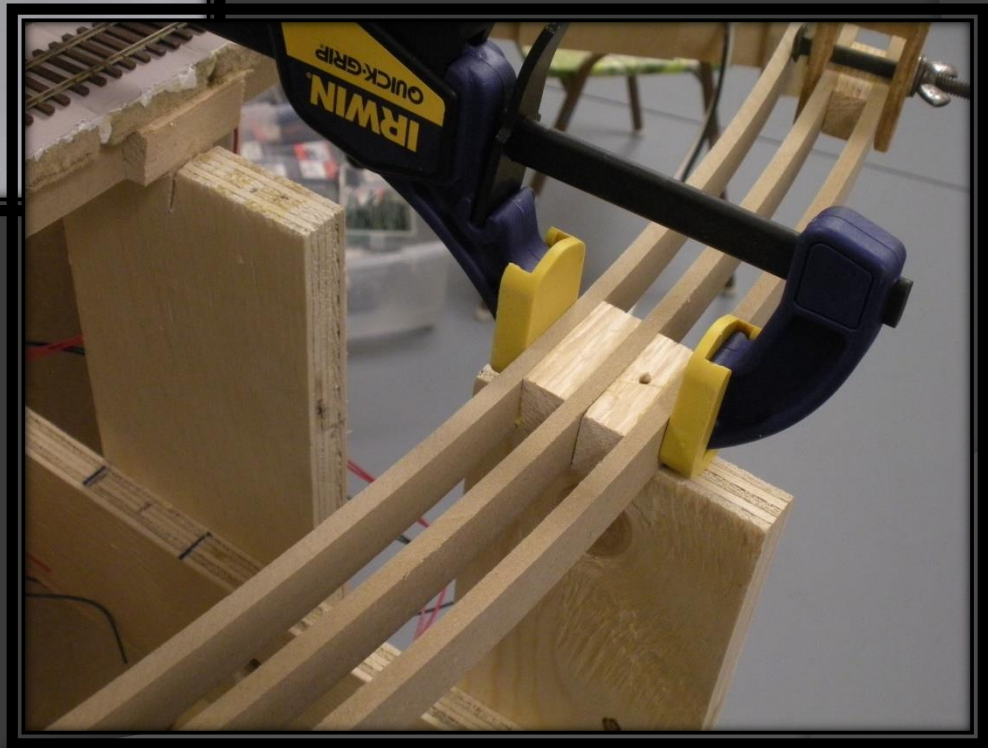
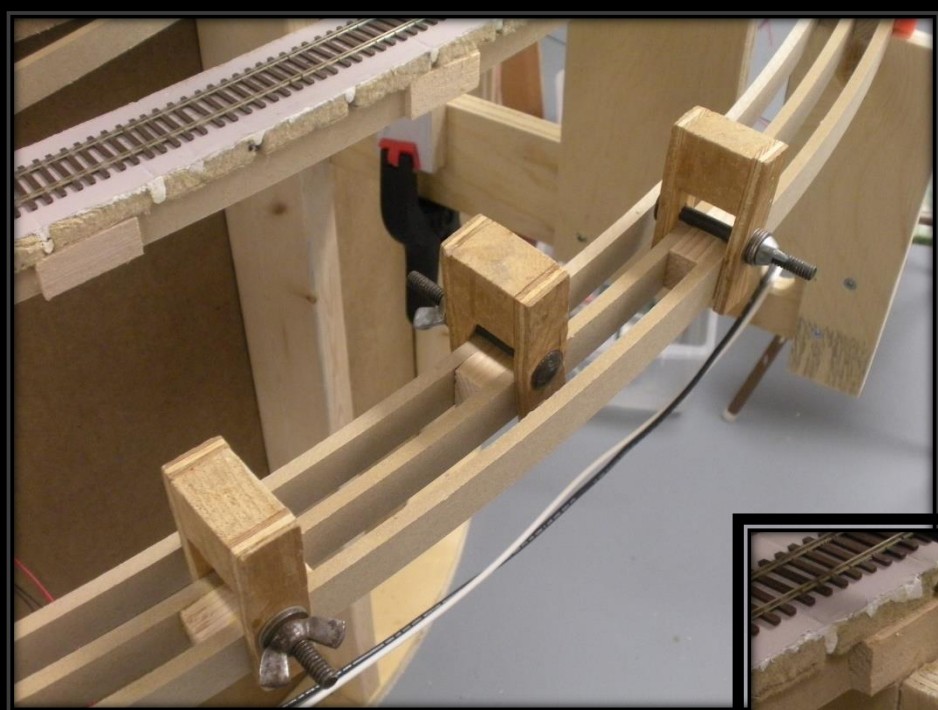







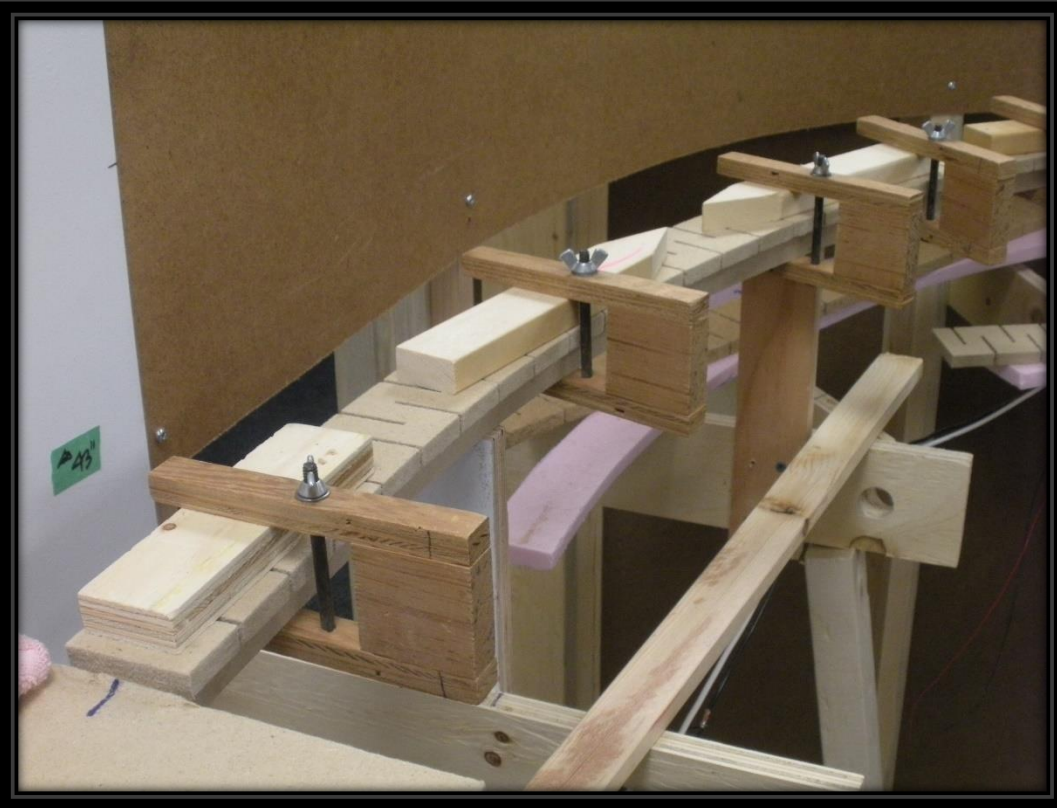



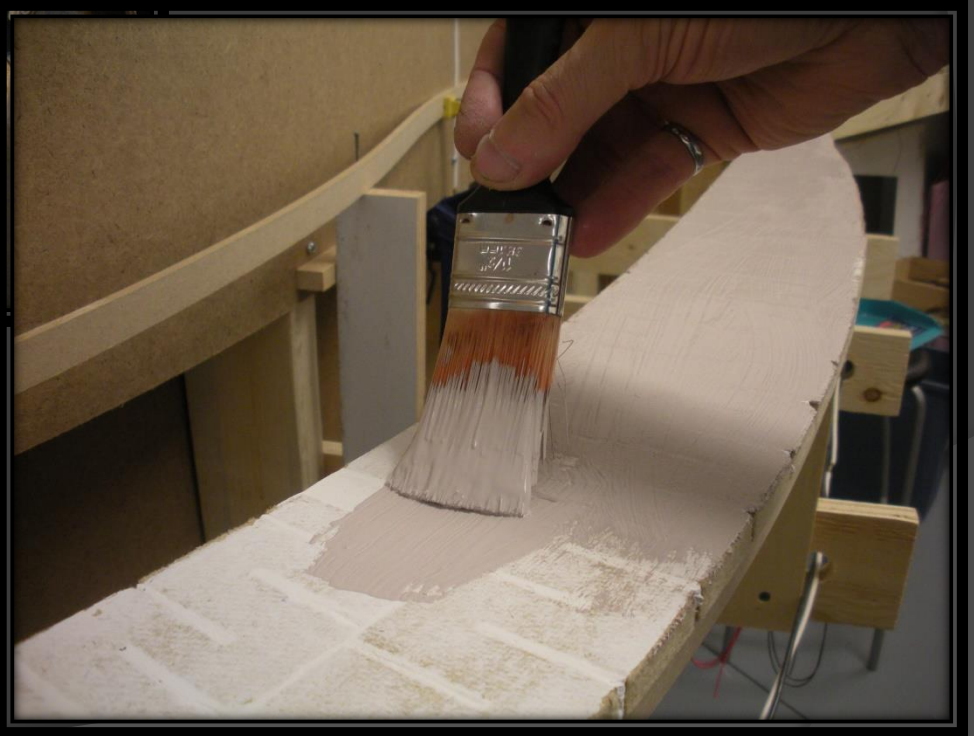

CORK ROADBED

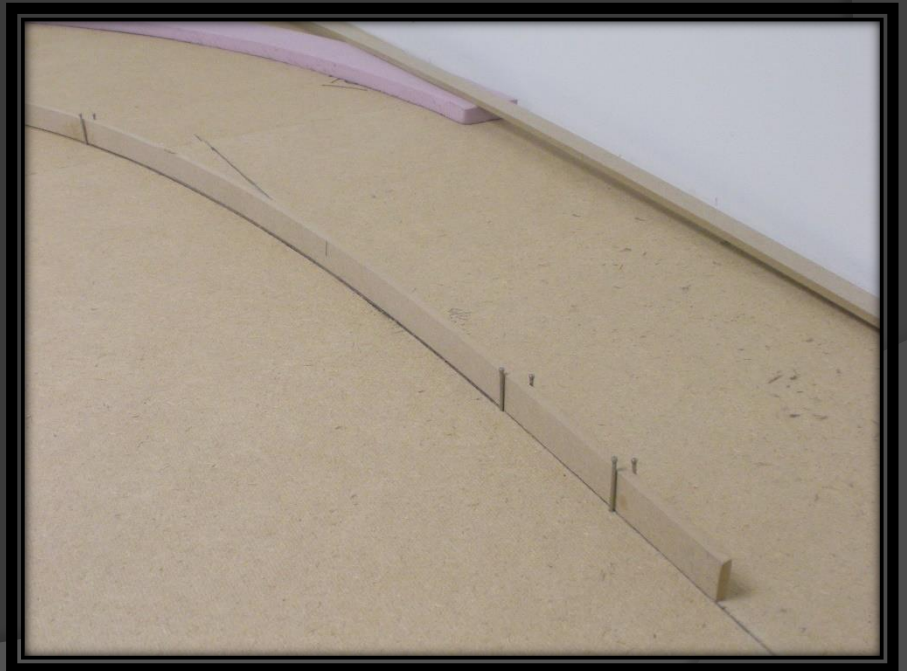

MINI ROULEAU DE LIEGE
MINI CORK ROLL

Facile à découper et à manipuler
 Le liège est idéal pour de multiples usages à la maison, au bureau et à l'atelier.

- ▶ Faites vos propres calettés pour l'été ou l'hiver
- ▶ Découpez vos propres sous-verres et sous-plats
- ▶ Évitez les égratignures en recouvrant la base de vos lampes, pots de fleurs, etc.
- ▶ Protégez le fond de vos tiroirs
- ▶ Essentiel pour le bricoleur

Easy to cut and handle
 Cork is perfect for many uses at home, at the office or at the shop.

- ▶ Make your own coasters for the summer or winter
- ▶ Cut your own coasters and table mats
- ▶ Avoid scratches by covering the bases of your lamps, flower pots, etc.
- ▶ Protect your drawer linings
- ▶ Essential for the do-it yourselfer

24" x 48" x 1/16"
 61 cm x 122 cm x 2 mm

www.sga.ca

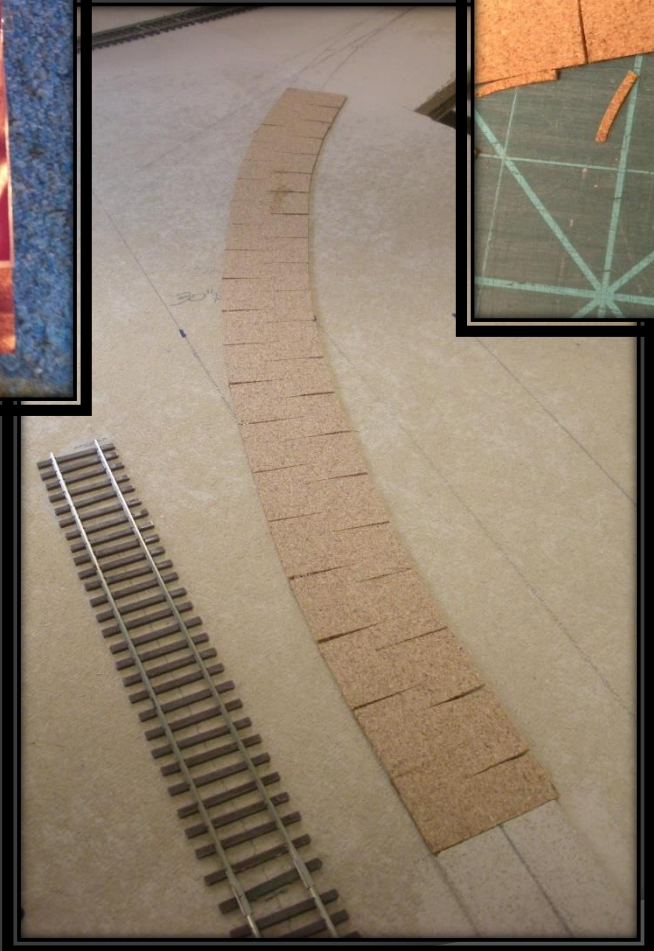
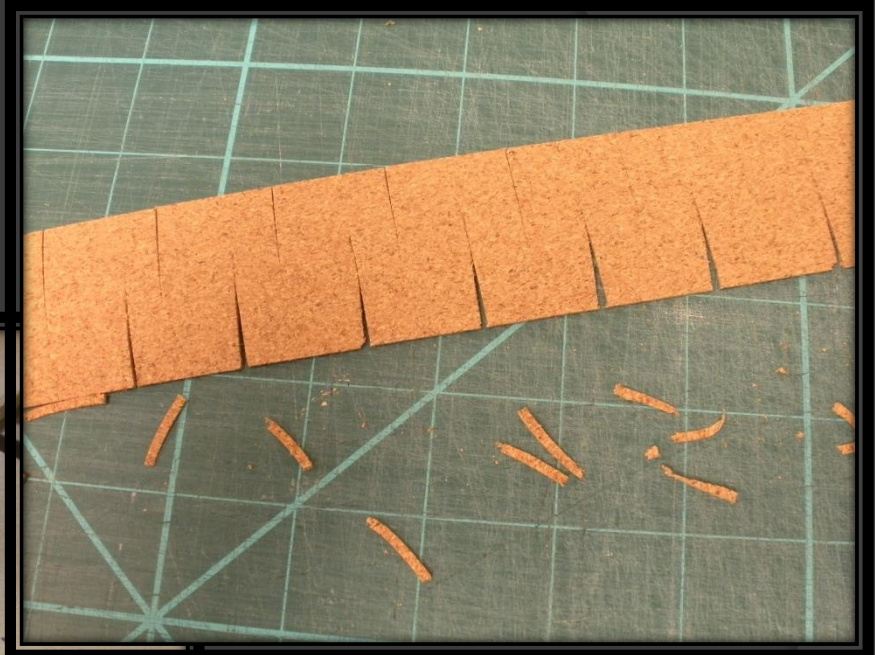

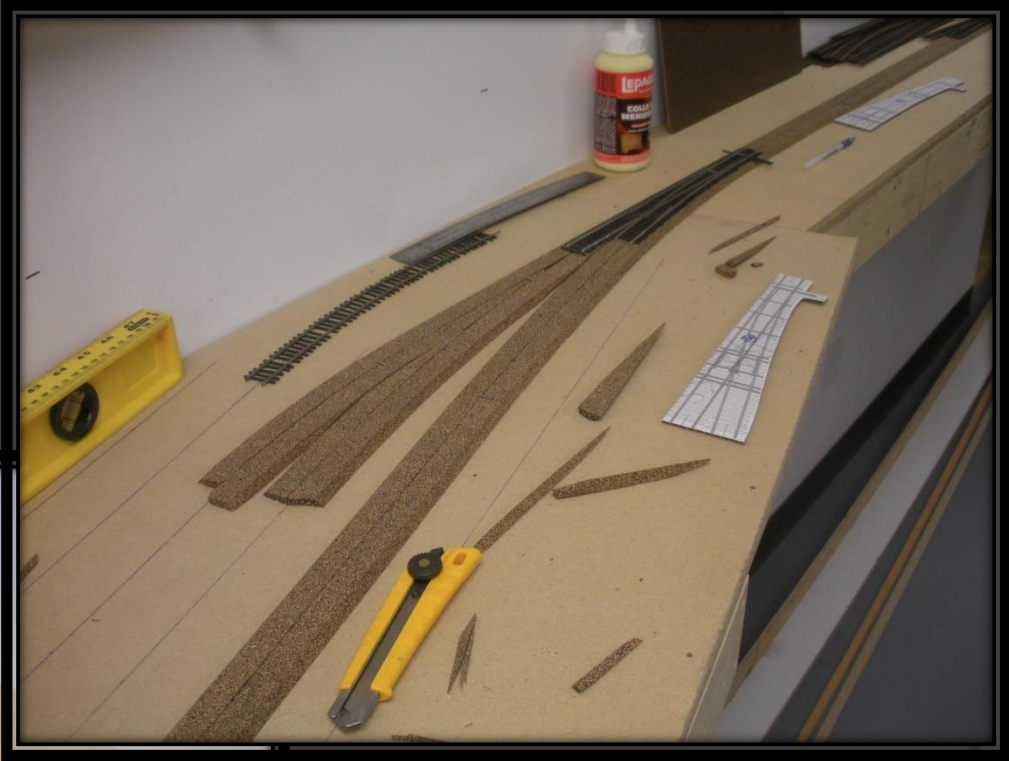







PRE-WIRING TECHNIQUES

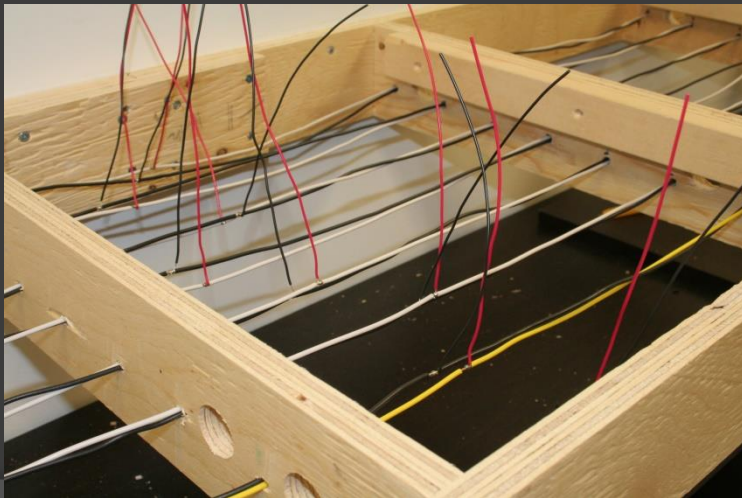

MISCELLANEOUS

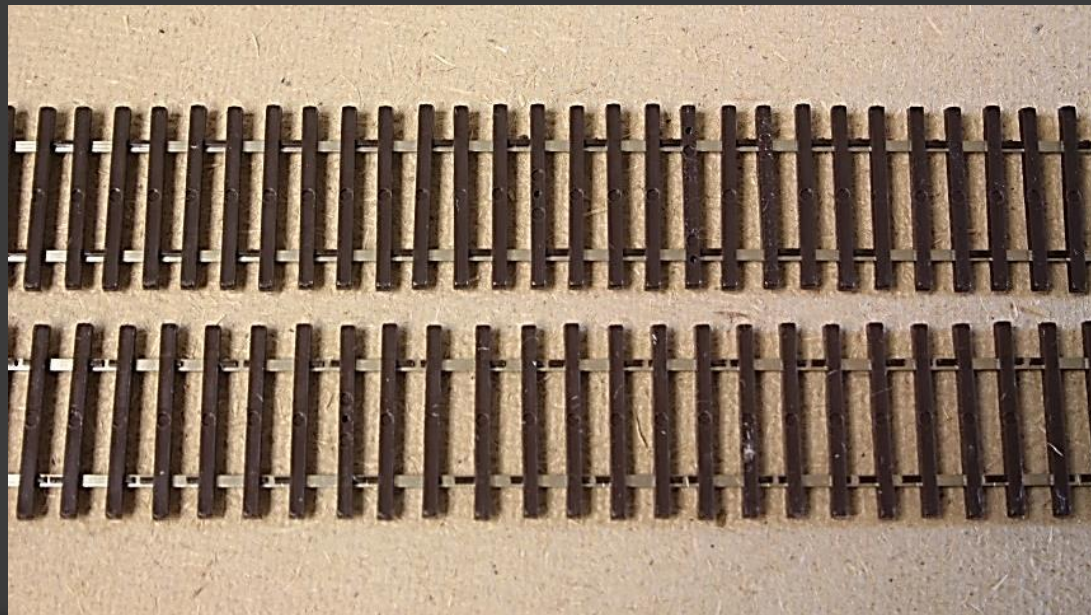
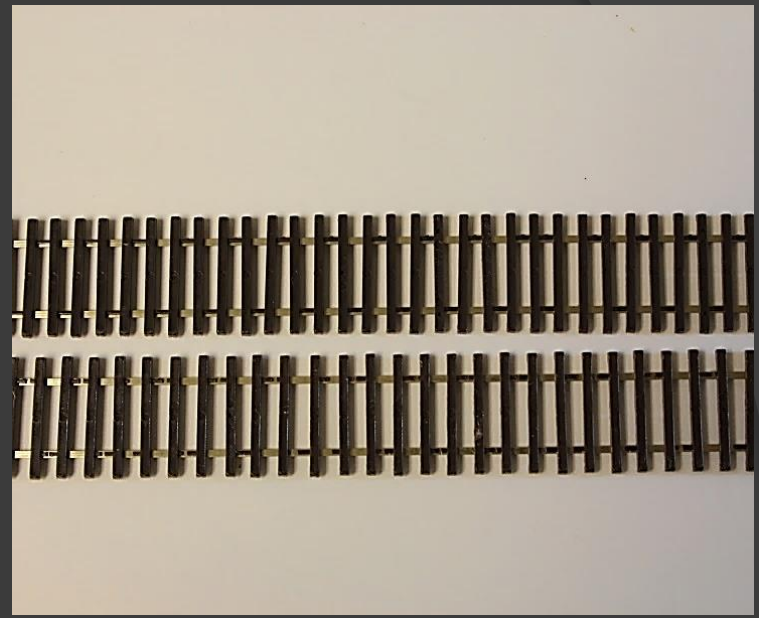
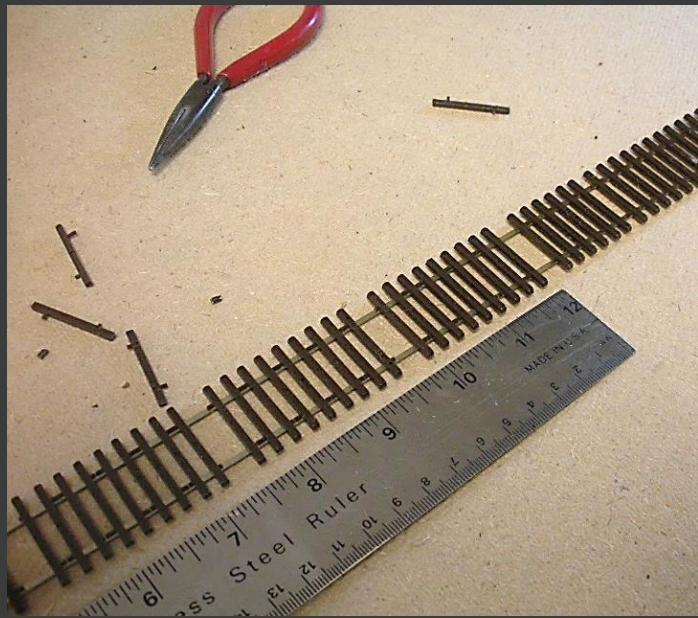





THANK YOU



WEB SITE;

www.cprboundarysub.ca

EMAIL;

scottcalvert@shaw.ca

